

FireLock NXT™ Dry Valve



SERIES 768

The patent-pending Victaulic Series 768 FireLock NXT Dry Valve is a low differential, latched clapper valve that uses a unique direct acting diaphragm to separate system water supplies from dry-pipe sprinkler systems.

* see page 12 for European trim



PATENT PENDING

FEATURES

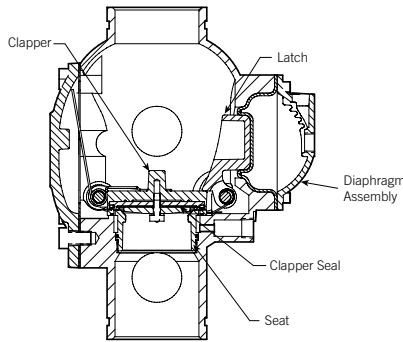

Exaggerated for clarity

Note: Valve is shown in the "set" position

The low differential, unique latch and actuator design of the valve allows the valve to be reset without opening the valve. The low differential design is not subject to water columns.

The valve allows the water to operate a water motor alarm and/or electric pressure alarms, which continue until the flow of water stops.

With the optional accelerator, the valve can be configured to respond faster for use in larger systems, or where faster response times are required.

The valve is rated to 300 psi/2065 kPa water working pressure and is factory tested hydrostatically to 600 psi/4135 kPa for sizes 1 1/2 – 8"/40 – 200mm. VdS trim configurations are approved to 16 BAR (see page 12). Required air pressure for all trim variations is 13 psi/90 kPa.

The Series 768 is available grooved x grooved. Standard grooved dimensions conform to ANSI/AWWA C606.

The Victaulic Series 768 FireLock NXT Dry Valve is made of high-strength, low-weight ductile iron, and it offers easy access to all internal parts. All internal parts are replaceable. Maintenance and service can be performed without removing the valve from its installed position. The rubber clapper seal is replaced easily without removing the clapper from the valve. The valve is painted inside and out to increase corrosion resistance.

The body is tapped for main drain and all available trim configurations.

Installation Options

The Victaulic Series 768 FireLock NXT Dry Valve is available bare, or in the following configurations:

Pre-trimmed

The pre-trimmed valve comes completely assembled with all necessary trim components.

Vic-Quick Riser

The Vic-Quick Riser comes completely pre-trimmed and includes a shut off valve (uses a Series 705W FireLock Butterfly valve – request publication 10.18; for 1 1/2 and 2"/40 and 50mm sizes, the Vic-Quick Riser comes with a Series 728 Ball Valve – request publication 10.17) for system shut off, pre-set pressure switches, and a drain kit for ease of installation. For complete Vic-Quick Riser information request publication 30.20.

Series 745 FireLock Fire-Pac (Available in North America only)

The Fire-Pac is a completely pre-assembled fire protection valve that provides maximum service in a minimal enclosed space. The unit includes a water supply shutoff valve, the sprinkler system fire protection valve, alarm line pressure switches, air supervisory pressure switches, supervisory pump switches, and digital pressure gauges that are easily viewed through a window in the cabinet door. For complete Fire-Pac information request publication 30.23.

Optional accessories ship separately.

JOB/OWNER	CONTRACTOR	ENGINEER
System No. _____	Submitted By _____	Spec Sect _____ Para _____
Location _____	Date _____	Approved _____
		Date _____

FireLock NXT™ Dry Valve

SERIES 768

DIMENSIONS

THE 4 INCH/114.3 MM UL LISTED, FM APPROVED CONFIGURATION IS SHOWN BELOW
 1½ - 2" / 48.3 - 60.3 MM CONFIGURATIONS CONTAIN ¾" / 19 MM DRAIN VALVES.
 2½ - 3" / 73.0 - 88.9 MM CONFIGURATIONS CONTAIN 1¼" / 31 MM DRAIN VALVES.
 4 - 8" / 114.3 - 219.1 MM CONFIGURATIONS CONTAIN 2" / 50 MM DRAIN VALVES.

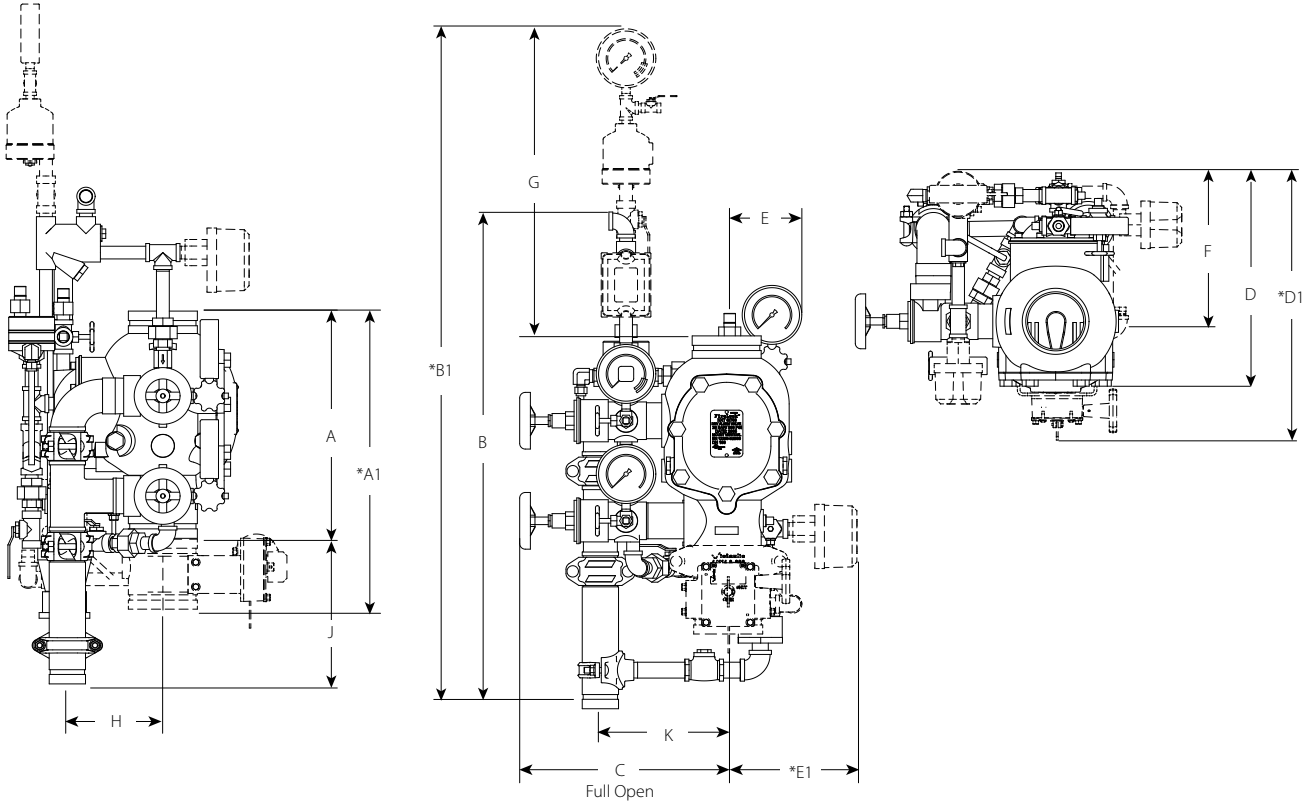

Size		Dimensions – inches/mm															Aprx. Weight Ea. lbs/kg	
Nominal Size Inches/mm	Actual Outside Diameter Inches/mm	A	A1	B	B1	C	D	D1	E	E1	F	G	H	J	K	Without Trim	With Trim	
1½ 40	1.900 48.3	9.00 228.60	16.43 417.32	27.25 692	39.50 1003	13.75 349	16.00 406	—	5.25 133	8.50 215	9.50 241	21.25 539	3.04 77.21	9.17 232.91	6.98 177.29	16.7 7.6	43.0 19.5	
2 50	2.375 60.3	9.00 228.60	16.43 417.32	27.25 692	39.50 1003	13.75 349	16.00 406	—	5.25 133	8.50 215	9.50 241	21.25 539	3.04 77.21	9.17 232.91	6.98 177.29	17.0 7.7	43.0 19.5	
2½ 65	2.875 73.0	12.61 320.29	16.50 419.10	32.25 819	44.25 1123	13.50 342	16.00 406	17.50 444	5.25 133	9.00 228	9.25 234	21.25 539	3.90 99.06	10.50 266.70	6.93 176.02	41.0 18.7	65.0 29.5	
76.1 mm	3.000 76.1	12.61 320.29	16.50 419.10	32.25 819	44.25 1123	13.50 342	16.00 406	17.50 444	5.25 133	9.00 228	9.25 234	21.25 539	3.90 99.06	10.50 266.70	6.93 176.02	41.0 18.7	65.0 29.5	
3 80	3.500 88.9	12.61 320.29	16.50 419.10	32.25 819	44.25 1123	13.50 342	16.00 406	17.50 444	5.25 133	9.00 228	9.25 234	21.25 539	3.90 99.06	10.50 266.70	6.93 176.02	41.0 18.7	65.0 29.5	
4 100	4.500 114.3	15.03 381.76	19.78 502.41	33.50 850	45.50 1155	15.00 381	15.75 400	20.50 520	5.25 133	9.00 228	10.75 273	21.00 533	6.25 158.75	9.62 244.34	8.46 214.88	59.0 26.7	95.0 43.0	
165.1 mm	6.500 165.1	16.00 406.40	22.00 558.80	34.00 863	46.00 1168	15.50 393	17.00 431	22.00 558	5.25 133	8.50 215	11.50 292	20.50 520	6.20 157.48	9.62 244.34	8.84 224.53	80.0 36.2	116.0 52.6	
6 150	6.625 168.3	16.00 406.40	22.00 558.80	34.00 863	46.00 1168	15.50 393	17.00 431	22.00 558	5.25 133	8.50 215	11.50 292	20.50 520	6.20 157.48	9.62 244.34	8.84 224.53	80.0 36.2	116.0 52.6	
8 200	8.625 219.1	17.50 444.50	22.94 582.67	33.50 850	45.50 1155	16.75 425	20.00 508	25.25 641	6.25 158	8.75 222	12.75 323	18.50 469	6.05 153.67	9.40 238.76	10.21 259.33	122.0 55.3	158.0 71.6	

NOTES:

The "A" dimension coupling is not shown in order to clarify dimensional callouts. Components shown as dotted lines denote optional equipment.

* Measurements denoted with an asterisk take optional equipment into account. Optional drain connection kit is shown for reference and takeout dimensions.

FireLock NXT™ Dry Valve

SERIES 768

PERFORMANCE

Hydraulic Friction Loss

The chart below expresses the flow of water at 65°F/18°C through a full open valve.

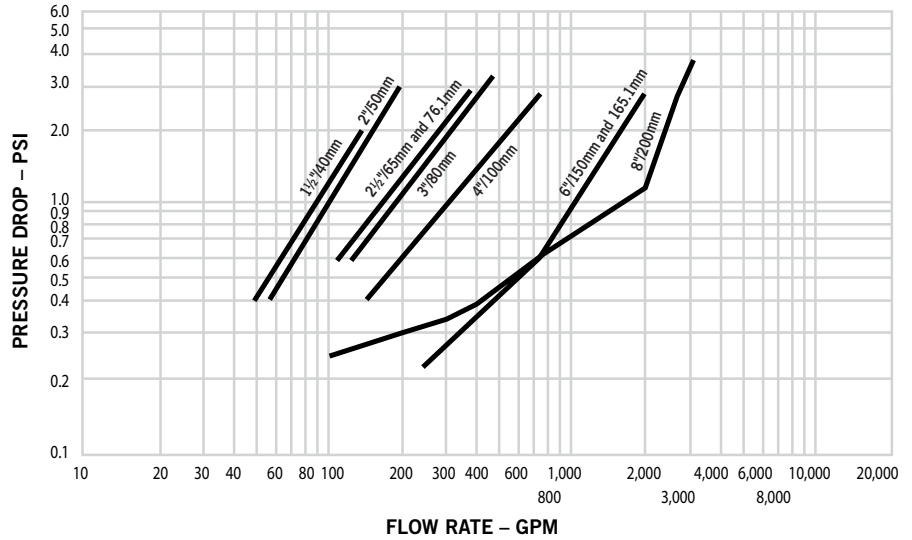

Frictional Resistance

The chart below expresses the frictional resistance of Victaulic Series 768 FireLock NXT Dry Valve in equivalent feet of straight pipe.

Size		Equivalent Length of Pipe
Nominal Size Inches/ mm	Actual Outside Dia. Inches/ mm	Feet meters
1 1/2 40	1.900 48.3	3.00 0.914
2 50	2.375 60.3	9.00 2.743
2 1/2 65	2.875 73.0	8.00 2.438
76.1 mm	3.000 76.1	8.00 2.439
3 80	3.500 88.9	17.00 5.182
4 100	4.500 114.3	21.00 6.401
165.1 mm	6.500 165.1	22.00 6.706
6 150	6.625 168.3	22.00 6.706
8 200	8.625 219.1	50.00 15.240

FireLock NXT™ Dry Valve

SERIES 768

C_v VALUES

C_v values for flow of water at +60°F/+16°C through a fully open valve are shown in the table below.

Formulas for C_v values:

$$\Delta P = \frac{Q^2}{C_v^2}$$

$$Q = C_v \times \sqrt{\Delta P}$$

Where:

Q = Flow (GPM)

ΔP = Pressure Drop (psi)

C_v = Flow Coefficient

Size		C _v /K _v (Fully Open Valve)
Nominal Size Inches/ mm	Actual Outside Dia. Inches/ mm	
1 ½ 40	1.900 48.3	60 52.0
2 50	2.375 60.3	110 95.0
2 ½ 65	2.875 73.0	180 156.0
76.1 mm	3.000 76.1	180 156.0
3 80	3.500 88.9	200 173.0
4 100	4.500 114.3	350 302.8
165.1 mm	6.500 165.1	1000 865.0
6 150	6.625 168.3	1000 865.0
8 200	8.625 219.1	1500 1499.1

OPERATION

The Series 768 Dry Valve contains a clapper, which has a replaceable rubber seal. The clapper makes contact with the valve's seat ring, which has access holes leading into an intermediate chamber in the valve. The diaphragm contacts the latch, and the latch holds the clapper closed.

In the closed position, the valve diaphragm is maintained in the extended position by the water supply pressure from upstream of the water supply control valve. The diaphragm latch holds the clapper in the closed position. The Series 776 Low Pressure Actuator (LPA) maintains the water, and the system's air pressure controls the LPA. Required air pressure is 13 psi/90 kPa. The design of the 776 actuator does not require the traditional air cushion of 10 – 20 psi/69 – 138 kPa. Excess air pressure above 13 psi/90 kPa will cause a delay in valve operation.

Once the system's air pressure reduces to the trip point, the LPA opens and allows the water supply pressure in the diaphragm to release (i.e. an open sprinkler). This release allows the latch to move to its open position, permitting the clapper to pivot freely, thus allowing water into the system.

Water enters the intermediate chamber of the valve through the holes in the seat ring. The water flows from the intermediate chamber to the alarm line, which activates the system's alarms. The alarms continue to sound until the flow of water stops.

When the flow of water stops, the spring-assisted valve clapper returns to the closed position. The valve acts as an alarm check valve until the system is back in service as a dry system, according to the proper procedure.

FireLock NXT™ Dry Valve

SERIES 768

MATERIAL SPECIFICATIONS

Body: Ductile iron conforming to ASTM A-536, grade 65-45-12. Ductile iron conforming to ASTM A-395, grade 65-45-15, is available upon special request.

Clapper: Aluminum bronze UNS-C95500

Latch: Aluminum bronze UNS-C95500

Shaft: Stainless 17-4

Clapper Seal: Peroxide cured EPDM, ASTM D2000

Bushings/Seat O-rings: Nitrile

Springs: Stainless Steel (300 Series)

Diaphragm: Peroxide cured EPDM with fabric reinforcement

Bill of Materials

1	Valve Body	12	Cover Plate
2	Clapper	13	Cover Plate Gasket
3	Clapper Seal	14	Cover Plate Bolts*
4	Seal Ring	15	Latch
5	Seal Washer	16	Latch Spring
6	Seal Retaining Ring	17	Latch Spring Bushing and O-ring (Qty. 2)
7	Seal Assembly Bolt	18	Diaphragm
8	Bolt Seal	19	Diaphragm Cover
9	Clapper Spring	20	Diaphragm Cover Cap Screws (Qty. 8)
10	Clapper Shaft	21	Latch Shaft
11	Clapper Shaft Bushing and O-ring (Qty. 2)		

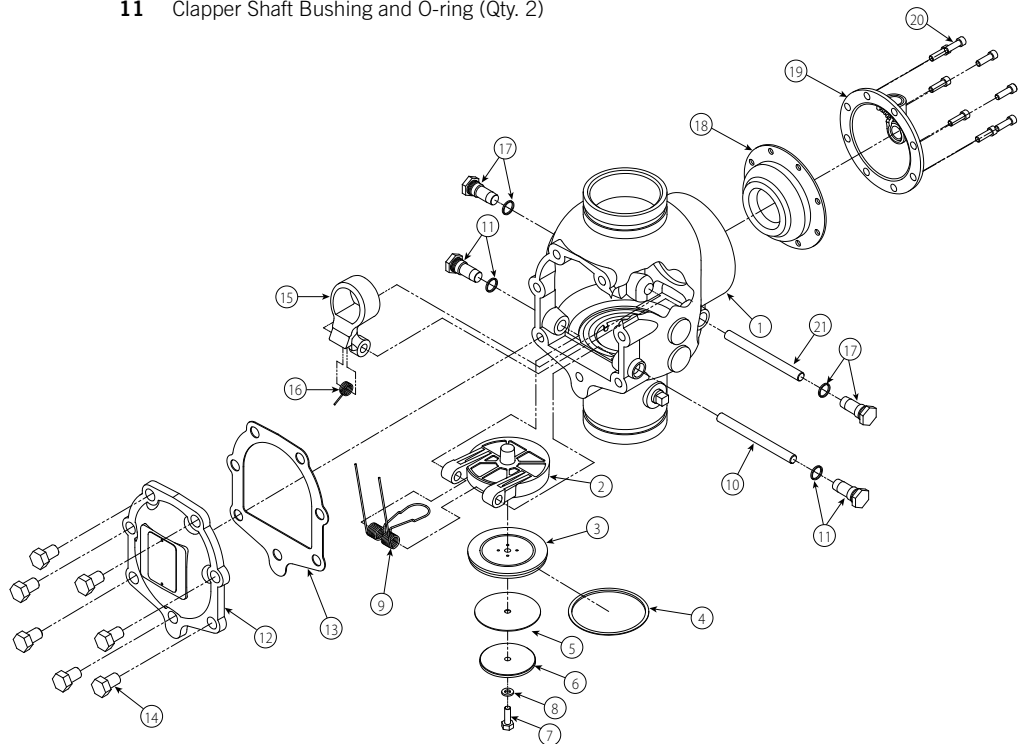

Exaggerated for clarity

* **NOTE:** The 1½-inch/48.3-mm and 2-inch/60.3-mm valve sizes contain washers under the heads of the cover plate bolts.

FireLock NXT™ Dry Valve

SERIES 768

TRIM PACKAGE DETAILS

Trim Packages:

NOTE: See page 11 for details of trim and page 12 for details of European trim.

- 1 Galvanized components
- 2 Series 776 Low-Pressure Actuator – The Series 776 Low-Pressure Actuator is pneumatically actuated and requires only 13 psi/90 kPa minimum air pressure, regardless of the system supply pressure. This actuator allows the system to operate with a low air or gas pressure of 7 psi/48 kPa. Request submittal 30.65.
- 3 All Required Pipe and Fittings
- 4 All Standard Trim Accessories
- 5 All Required Gauges

Optional Trim Package:

- 1 Black Trim for Foam Systems – If the valve is intended for use in a foam system, black trim must be ordered, per NFPA requirements. Specify this requirement on the order.

Optional Accessories:

- **Series 746-LPA Dry Accelerator** – The Series 746-LPA Dry Accelerator is required when the Series 768 Dry Valve is installed in large systems to improve response time. Request submittal 30.64.
- **Series 760 Water Motor Alarm** – The Series 760 Water Motor Alarm is a mechanical device that sounds when a sustained flow of water occurs (such as with an open sprinkler). Request submittal 30.32.
- **Series 75B Supplemental Alarm Device** – The Series 75B Supplemental Alarm Device is designed to provide a continuous alarm for systems equipped with a mechanical device. Request submittal 30.33.
- **Series 75D Water Column Kit** – The Series 75D Water Column Kit is designed to minimize residual water in the riser from collecting above the clapper. Request submittal 30.34.
- **Alarm Pressure Switch** – Alarm Pressure Switches are designed to activate electrical alarms and control panels when a sustained flow of water occurs (such as with an open sprinkler).
- **Air Supervisory Pressure Switch** – Air Pressure Supervisory Switches are used to monitor low system air pressure and are factory pre-set.
- **Air Supply System** – The air supply system contains all components for establishing and maintaining air in the system. The compressor, low-pressure alarms, ball valves, and required trim are included in the air supply system.
- **Air Compressor** (See page 8 for more on the Victaulic Series 7C7 Compressor Package)
- **Air Maintenance Trim Assembly**
- **Alarm Panels**
- **Drain Connection Kit**

FireLock NXT™ Dry Valve

SERIES 768

AIR SUPPLY REQUIREMENTS

The required air pressure for Series 768 FireLock NXT Dry Valves is 13 psi/90 kPa minimum, regardless of the system supply water pressure. Air pressures should be kept below 18 psi/124 kPa, unless a Series 746-LPA Dry Accelerator is installed. Systems with air pressures higher than 18 psi/124 kPa may require the addition of a Series 746-LPA Dry Accelerator.

If multiple Series 768 FireLock NXT Dry Valves are installed with a common air supply, isolate the systems with a spring-loaded, soft-seated ball check valve to ensure air integrity for each system. Good practice is to include a ball valve for isolation and service of each individual system.

The engineer/system designer is responsible for sizing the compressor so that the entire system is charged to the required air pressure within 30 minutes. DO NOT oversize the compressor to provide more airflow. An oversized compressor will slow down or possibly prevent valve operation.

If the compressor fills the system too fast, it may be necessary to restrict the air supply. Restricting the air supply will ensure that air being exhausted from an open sprinkler or manual release valve is not replaced by the air supply system as fast as it is being exhausted.

COMPRESSOR SIZING

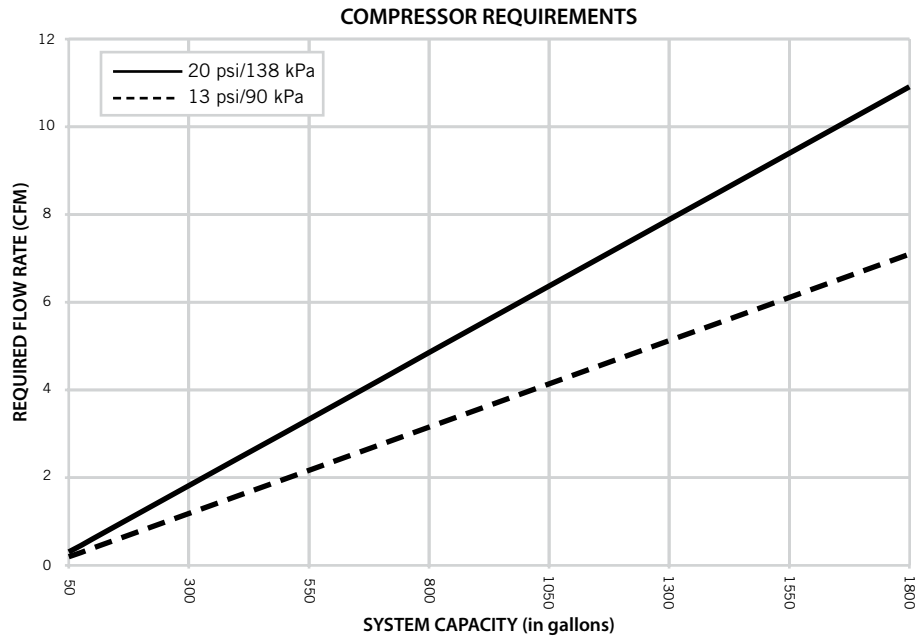

FireLock NXT™ Dry Valve

SERIES 768

BASE OR RISER-MOUNTED COMPRESSORS

For base or riser-mounted compressors, the recommended air pressure of 13 psi/90 kPa is the “on” or “low” pressure setting for the compressor. The “off” or “high” pressure setting should be 18 psi/124 kPa. Victaulic offers the Series 7C7 Compressor package for FireLock NXT devices which is riser-mounted and pre-set for the FireLock NXT pressure requirements as stated above. For information on the Series 7C7 package, consult publication 30.22. The Series 7C7 Compressor package is only available in North America.

When a base or riser-mounted air compressor supplies air to a Series 768 FireLock NXT Dry Valve, it is not necessary to install the Victaulic Series 757 Regulated Air Maintenance Trim Assembly (AMTA). In this case, the airline of the compressor connects to the trim at the fitting where the Series 757 Regulated AMTA is normally installed (refer to the applicable trim drawing). If the compressor is not equipped with a pressure switch, the Series 757P Air Maintenance Trim Assembly with Pressure Switch should be installed. For information on the Series 757 Regulated Air Maintenance Trim Assembly, see publication 30.35. For information on the Series 757P Air Maintenance Trim Assembly, see publication 30.36.

SHOP AIR OR TANK-MOUNTED AIR COMPRESSORS

In the event a compressor becomes inoperative, a properly sized tank-mounted air compressor provides the the greatest protection for systems.

When shop air or a tank-mounted air compressor is used, the Series 757 Regulated AMTA must be installed. The Series 757 Regulated AMTA provides proper air regulation from the air reservoir to the sprinkler system.

For tank-mounted air compressors, the recommended air pressure of 13 psi/90 kPa should be used as the set point for the air regulator. The “on” pressure of the compressor should be at least 5 psi/ 34 kPa above the set point of the air regulator.

FireLock NXT™ Dry Valve

SERIES 768

SERIES 757 REGULATED AIR
MAINTENANCE TRIM ASSEMBLY

NOTICE

- Victaulic recommends a maximum of two Series 768 FireLock NXT Dry Valves per Series 757 Regulated AMTA

Bill of Materials

- | | |
|---|---|
| 1 | 1/8" / 3.2 mm Restrictor |
| 2 | Slow Fill Ball Valve (Normally Open) |
| 3 | Air Regulator |
| 4 | Strainer (100 Mesh) |
| 5 | Spring-Loaded, Soft-Seated Ball Check Valve |
| 6 | Fast Fill Ball Valve (Normally Closed) |

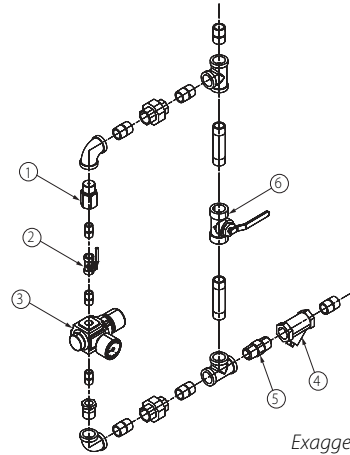

Exaggerated for clarity

SERIES 757P AIR MAINTENANCE TRIM
ASSEMBLY WITH PRESSURE SWITCH

NOTICE

- Victaulic recommends a maximum of two Series 768 FireLock NXT Dry Valves per Series 757P AMTA with Pressure Switch

Bill of Materials

Item	Qty.	Description
1	1	Restrictor (1/2-inch NPT)
2	1	Strainer (1/2-inch NPT)
3	1	Swing Check (1/2-inch NPT)
4	1	Slow-Fill Ball Valve (Normally Open)
5	1	Spring-Loaded, Soft-Seated Check Valve
6	1	Pressure Switch
7	2	Compression Fitting, Straight (1/4-inch NPT x 1/4-inch Tube)
8	1	Copper Tubing (1/4-inch OD)
9	11	Close Nipple (1/2-inch NPT x 1.13)
10	1	Nipple (1/2-inch NPT x 4.00)
11	1	90° Female Elbow (1/2-inch NPT)
12	4	Female Tee (1/2-inch NPT)
13	3	Union (1/2-inch NPT)
14	2	Reducing Bushing (1/2-inch NPT x 1/4-inch NPT)
15	1	Fast-Fill Ball Valve (Normally Closed)
16	1	Pressure Switch Isolation Ball Valve (Normally Open - Lockable)

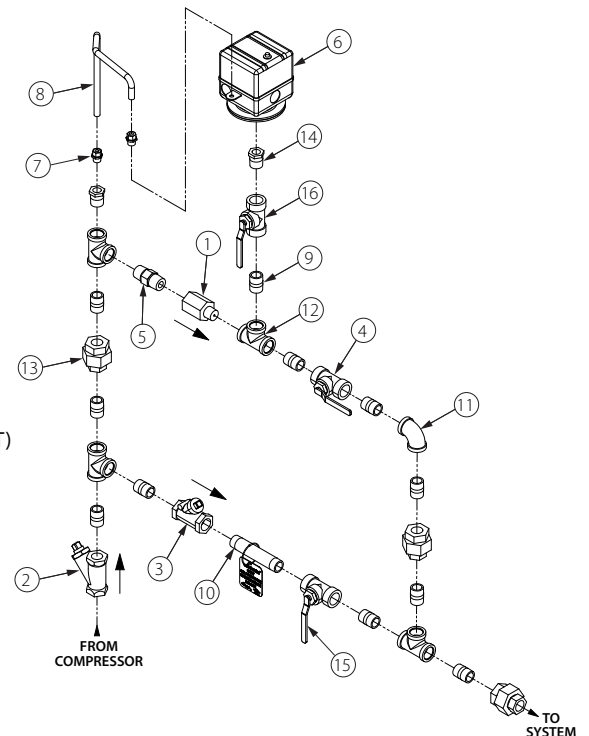

Exaggerated for clarity

FireLock NXT™ Dry Valve

SERIES 768

COMPRESSOR REQUIREMENTS

Compressor Requirements and Settings for Series 768 FireLock NXT Dry Valves Installed with Series 746-LPA Dry Accelerators

Set the air regulator of the Series 757 Regulated AMTA to 13psi/90kPa.

THE SERIES 757P AIR MAINTENANCE TRIM ASSEMBLY WITH PRESSURE SWITCH MUST NOT BE USED ON A SERIES 768 FIRELOCK NXT DRY VALVE INSTALLED WITH A SERIES 746-LPA DRY ACCELERATOR.

When a Series 768 FireLock NXT Dry Valve is installed with a Series 746-LPA Dry Accelerator, the Series 757 Regulated AMTA must be used. **NOTE:** The use of an air regulator with a base or riser-mounted compressor could cause short cycling, resulting in premature wear of the compressor.

In the event a compressor becomes inoperative, a properly sized tank-mounted air compressor provides the greatest protection for systems installed with a Series 746-LPA Dry Accelerator. In this situation, air can be supplied continuously to the sprinkler system for an extended time period.

NOTE: The Series 757 Regulated AMTA must be used with a tank-mounted air compressor or shop air system that continually supplies air to a Series 768 FireLock NXT Dry Valve installed with a Series 746-LPA Dry Accelerator.

The air regulator of the Series 757 Regulated AMTA is a relief-type design. Any pressure in the system that is above the set point of the air regulator will be released. Therefore, charging the air regulator above the set point could cause premature operation of a valve installed with a Series 746-LPA Dry Accelerator. **NOTE:** The series 746-LPA should not be used above 30psi. If higher pressures are required, the series 746 should be used.

Settings for Air Supervisory Pressure Switches and Alarm Pressure Switches

Air supervisory pressure switches are required for dry systems and must be set according to the following instructions. **NOTE:** Switches for Vic-Quick Risers are pre-set at the factory.

Wire the air supervisory pressure switches to activate a low-pressure alarm signal. **NOTE:** In addition, the local authority having jurisdiction may require a high-pressure alarm. Contact the local authority having jurisdiction for this requirement.

Set the air supervisory pressure switches to activate at 2 – 4psi/14 – 28kPa below the minimum air pressure required, but not lower than 10psi/69kPa.

Wire the alarm pressure switch to activate a water flow alarm.

Set the alarm pressure switch to activate on a pressure rise of 4 – 8psi/28 – 55kPa.

Remote System Test Valve Requirements

The remote system test valve (inspector's test connection) should contain a UL Listed and/or FM Approved valve (normally closed), which can be opened to simulate the operation of a sprinkler.

The remote system test valve (inspector's test connection) should be located at the most hydraulically demanding location in the release system. **NOTE:** Multiple restrictions on the remote system test valve (inspector's test connection) may slow the air decay rate and cause the system to respond slower than required.

The remote system test valve (inspector's test connection) should terminate with an orifice equal to the smallest orifice in the releasing system.

The remote system test valve (inspector's test connection) is used to ensure that water reaches the most remote part of the system within 60 seconds.

FireLock NXT™ Dry Valve

SERIES 768

EXPLODED VIEW DRAWING – TRIM COMPONENTS

(UL LISTED) (FM TRIM)

Series 768 FireLock NXT Dry Valve
(Optional Accessories Also Shown)

Bill of Materials

- 1 Series 768 FireLock NXT Dry Valve
- 2 FireLock Rigid Coupling (Optional/Sold Separately – Comes Standard when VQR Assembly is Ordered)
- 3 Water Supply Main Control Valve (Optional/Sold Separately – Comes Standard when VQR Assembly is Ordered)
- 4 Drain Swing Check Valve
- 5 Drip Cup with Cap
- 6 Alarm Pressure Switch (Optional/Sold Separately – Comes Standard when VQR Assembly is Ordered)
- 7 Series 729 Drip Check Valve
- 8 Diaphragm-Charge-Line Ball Valve (Normally Open)
- 9 3-in-1 Strainer/Check/Restrictor Assembly
- 10 Series 760 Water Motor Alarm (Optional/Sold Separately)
- 11 Alarm Test Ball Valve
- 12 Diaphragm-Charge-Line Pressure Gauge (0-300 psi/0-2068 kPa/0-20.7 Bar)
- 13 Series 749 Auto Drain
- 14 Series 746-LPA Dry Accelerator Assembly (Optional/Sold Separately)
- 15 Series 776 Low-Pressure Actuator
- 16 Air Manifold
- 17 Air Supervisory Pressure Switch (Optional/Sold Separately – Comes Standard when VQR Assembly is Ordered)
- 18 System Pressure Gauge (0-80 psi/0-552 kPa/0-5.5 Bar with Retard)
- 19 Water Supply Main Drain Valve - Flow Test
- 20 Water Supply Pressure Gauge (0-300 psi/0-2068 kPa/0-20.7 Bar)
- 21 Drain Connection Kit (Optional/Sold Separately – Comes Standard when VQR Assembly is Ordered)
- 22 Gauge Valve
- 23 System Main Drain Valve
- 24 Series 748 Ball Check Valve

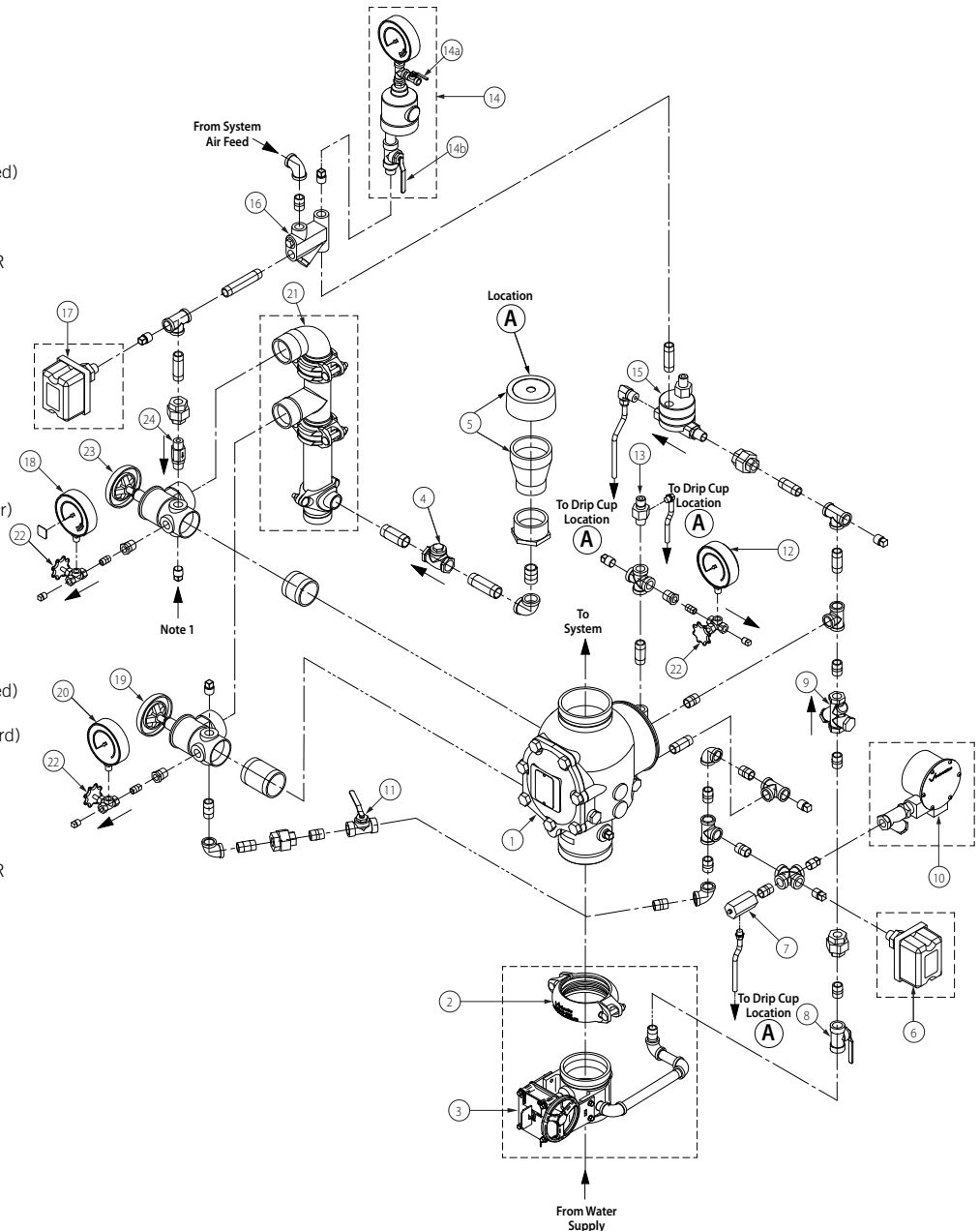

Exaggerated for clarity

Optional devices include the Series 75D Water Column Device Kit and the Series 75B Supplemental Alarm Kit.

NOTE 1: Connection point for the Series 75D Water Column Device Kit.

For installation of the Series 75B Supplemental Alarm Device, refer to the instructions supplied with the product.

FireLock NXT™ Dry Valve

SERIES 768

**EXPLODED VIEW DRAWING –
TRIM COMPONENTS**

(EUROPEAN TRIM c (UL) US (FM) LPCB 0832 (VdS) (VNIPO))

Series 768 FireLock NXT Dry Valve
(Optional Accessories Also Shown)

Bill of Materials

- 1 Series 768 FireLock NXT Dry Valve
- 2 FireLock Rigid Coupling (Optional/Sold Separately – Comes Standard when VQR Assembly is Ordered)
- 3 Water Supply Main Control Valve (Optional/Sold Separately – Comes Standard when VQR Assembly is Ordered)
- 4 Drain Swing Check Valve
- 5 Drip Cup with Cap
- 6 Alarm Pressure Switch (Optional/Sold Separately – Comes Standard when VQR Assembly is Ordered)
- 7 Series 729 Drip Check Valve
- 8 Diaphragm-Charge-Line Ball Valve (Normally Open)
- 9 3-in-1 Strainer/Check/Restrictor Assembly
- 10 Series 760 Water Motor Alarm (Optional/Sold Separately)
- 11 Alarm Test Ball Valve
- 12 Diaphragm-Charge-Line Pressure Gauge (0 – 300 psi/0 – 2068 kPa/0 – 20.7 Bar)
- 13 Series 749 Auto Drain
- 14 Series 746-LPA Dry Accelerator Assembly (Optional/Sold Separately)
- 15 Series 776 Low-Pressure Actuator
- 16 Air Manifold
- 17 Air Supervisory Pressure Switch (Optional/Sold Separately – Comes Standard when VQR Assembly is Ordered)
- 18 System Pressure Gauge (0 – 80 psi/0 – 552 kPa/0 – 5.5 Bar with Retard)
- 19 Water Supply Main Drain Valve – Flow Test
- 20 Water Supply Pressure Gauge (0 – 300 psi/0 – 2068 kPa/0 – 20.7 Bar)
- 21 Drain Connection Kit (Optional/Sold Separately – Comes Standard when VQR Assembly is Ordered)
- 22 Gauge Valve
- 23 System Main Drain Valve
- 24 Series 748 Ball Check Valve
- 25 Water Motor Alarm Shutoff Valve (Normally Open)*

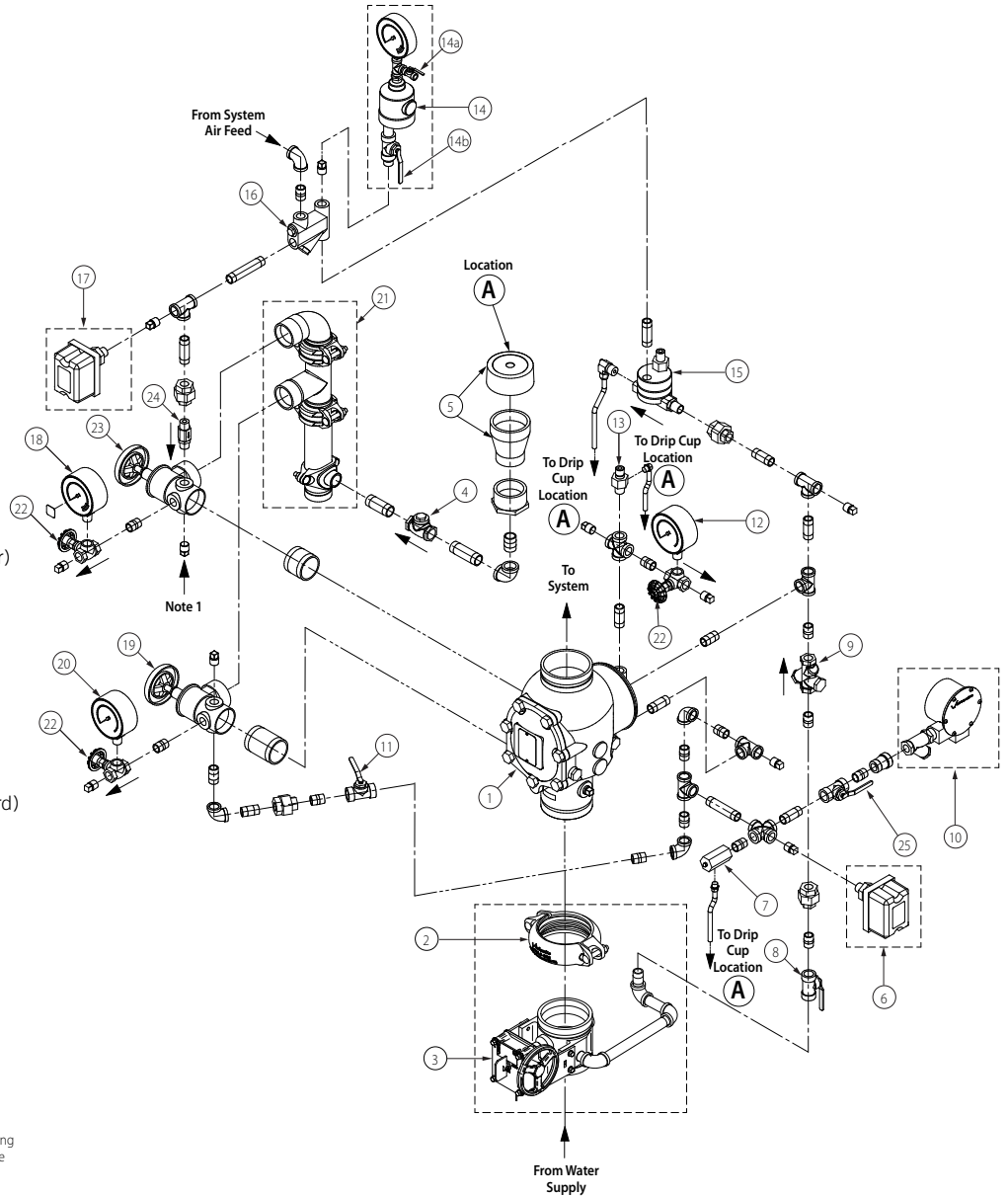

*Item 25, water motor alarm shutoff valve, can be closed to prevent water from flowing into the Series 760 Water Motor alarm during conditions that are not favorable for the alarm to sound (i.e. during a trip test).

FireLock NXT™ Dry Valve

SERIES 768

FireLock NXT™ Dry Valve

SERIES 768

FireLock NXT™ Dry Valve

SERIES 768

FireLock NXT™ Dry Valve

SERIES 768

WARNING



WARNING



• This product must be installed by an experienced, trained installer, in accordance with the instructions provided with each valve. These instructions contain important information.

Failure to follow these instructions may result in serious personal injury, property damage, or valve leakage.

If you need additional copies of this product literature or the valve installation instructions, or if you have any questions about the safe installation and use of this device, contact Victaulic Company, P.O. Box 31, Easton, PA 18044-0031 USA, Telephone: 001-610-559-3300.

WARRANTY

Refer to the Warranty section of the current Price List or contact Victaulic for details.

NOTE

This product shall be manufactured by Victaulic or to Victaulic specifications. All products to be installed in accordance with current Victaulic installation/assembly instructions. Victaulic reserves the right to change product specifications, designs and standard equipment without notice and without incurring obligations.



WCAS-7BCHWM

For complete contact information, visit www.victaulic.com

30.80 4219 REV F UPDATED 3/2008

VICTAULIC IS A REGISTERED TRADEMARK OF VICTAULIC COMPANY. © 2008 VICTAULIC COMPANY. ALL RIGHTS RESERVED.

